



RGPBALLS®

BALL TRANSFER UNITS

www.rgpballs.com

Welcome



COMPANY PROFILE

WELCOME TO OUR WORLD: PRECISION.

For over fifty years, we have been among Europe's leading companies in the manufacturing, trading and distribution of precision balls, rollers and ball transfer units.

WE MOVE MOUNTAINS TO GET THE DETAILS PERFECT

Over 70 people working together since long time in our headquarter in Cinisello Balsamo: at Rgpballs we have about 10,000 m² of know-how and expertise. We consistently work on innovations to stay at the forefront. With us, everything is about quality.

CHOOSING RGPBALLS® MEANS CHOOSING EXPERTISE, ...

Nothing says more than time. We have over 50 years of efforts, breakthroughs, and expertise under our belts. And we keep improving everyday.

METHOD, ...

Science pushes us far, a consultative spirit keeps us close to your needs. And this is how we manage to handle the broadest range of inquiries.

SPEED.

Time is valuable, exactly like our warehouse.

Indeed, more stock available means less time needed to satisfy any demand.

AN "EVERYTHING, RIGHT NOW" WAREHOUSE.

You also know that in an ever-changing business, speed is competitiveness.

Our warehouse is a valuable resource with more than 5,000 tons of products regularly in stock.

We can guarantee prompt delivery for most of our customers' needs worldwide.

WE HAVE MORE THAN 3,000 CUSTOMERS ALL AROUND THE WORLD, AND WE SPEAK THEIR LANGUAGES.

Our catalogue is international; wherever you are, you can select our products and consult with our experts, without worrying about physical or language barriers.

Our team can speak all major languages: Italian, German, English, French, Spanish, Ukrainian, Russian, Chinese, and Romanian.

A FAMILY BUSINESS.

We are a company that is also a big family. You won't find any board of directors with us, only the passion we put into each and every challenge. Our business is so stable that after 50 years we are still here, with all the professionalism of an international business.

10.000
m² headquarter

80
employees

4.000
tons of products

+3.000
customers

CERTIFICATION:

CERTIFICATION FOR MANAGEMENT SYSTEMS:

ISO 9001:2015 – ISO 14001:2015 – ISO 45001:2018

PRODUCT CERTIFICATION ACCORDING TO TUV-PROFICERT PROCEDURES

APPLICATIONS

RGPBALLS® BALL TRANSFER UNITS

They are used in a vast number of applications.

Whether you are a small company or a multinational one, we are by your side to make your job easier and your applications more performing. A few of the most common include:

Airport loading and unloading equipment

Sheet metal processing machinery

Hydraulic presses

Sliding guides

Elevating platforms and equipment

Mechanical conveyors

Marble and ceramic processing machinery

Transport trolleys

Pallet and container racks

Movable walls

Sliding gates

Sliding doors and windows

Equipment for robotics, electronics and general automation

Car stands



HOW TO SELECT THE CORRECT PRODUCT FIRST OBSERVATIONS

ASPECTS TO BE EVALUATED

- **Position and assembly of the component:** the product can be assembled with the load ball facing upwards, downwards or according to the type of use required.
- **Working temperature:** depending on what type of material they are made of, the balls can react to loads in different ways.
- **Working environment:** different contaminating factors (dirt, dust, humidity etc.) can influence the yield of the product.
- **Load** (size, hardness, surface, stability etc.) to which the product will be subjected.
- **Additional aspects such as speed, frequency and duration** of the loads handled.

POSITIONING

Fixing and positioning are performed with the usual insertion in pre-established holes or resting on the base, by means of screws and rivets in the versions with fixing holes or through internal or external threads. Two versions of fixing rings in fixed or removable types are available for locking in the seats. We also have a special a version (called SPM-R) with a predetermined height groove for the insertion of the fixing rings according to DIN 471, which allows the locking in holes made on support surfaces of variable thickness. On request it is possible to make this groove at different heights and on different types of transfer balls.

LAYOUT

Usually ball transfer units are used with three layouts:

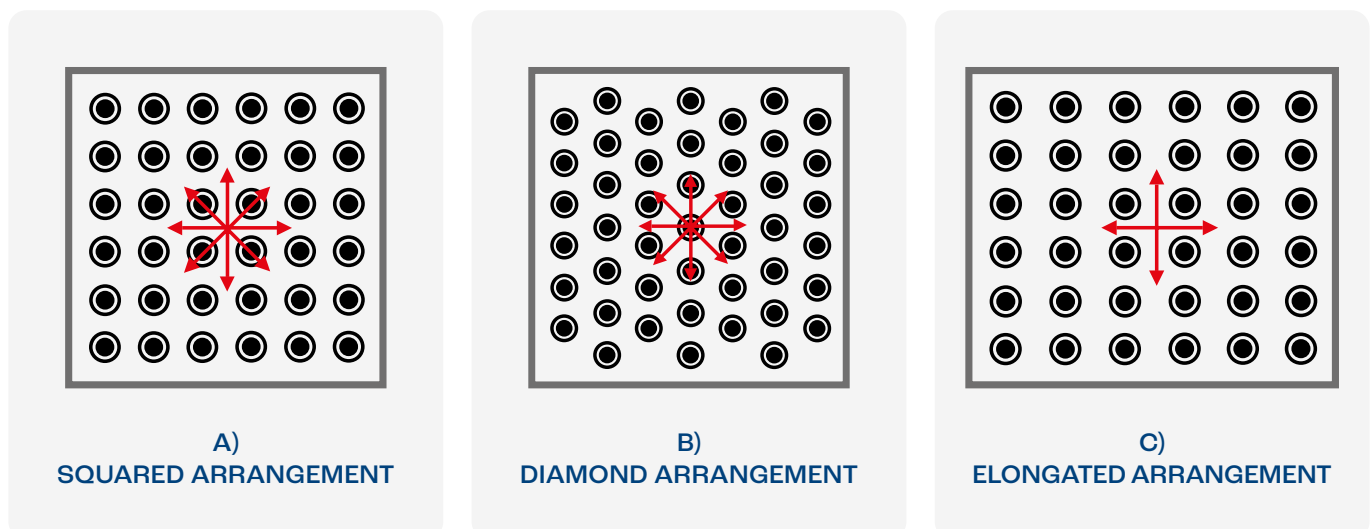

CONSTRUCTION

RGPBALLS® ball transfer units are multidirectional systems for the linear handling of loads.

They consist of a large ball that rolls on a defined quantity of small diameter balls, all enclosed in a hemispherical seat.

Thanks to the care with which the various components are processed, friction is particularly low, thus allowing the strength required to move the loads to be significantly reduced.

The production range starts with a main ball of 12 mm diameter up to a maximum of 90 mm, which can be made of different types of materials such as steel, stainless steel, pressed metal sheet and plastic materials. Among the versions made, different types of coatings are also available, which are useful to preserve oxidation resistance over time.

Even the balls used can be chosen from different types of materials according to the final application. All components can be assembled in different materials, to meet any specific final use.

RGPBALLS® mainly produces two “families” of ball transfer units:

- **Hardened machined steel housing (turned from bar):** - they are normally used to handle heavy loads, strong stresses, impacts and severe conditions in general. For high flow rates, similar versions are available specifically designed for these applications.
- **Pressed metal sheet components:** - they are instead preferable in applications which involve lower loads. They combine good smoothness at adequate flow rates, allowing a cheaper final price.
- **with plastic material components** - suitable for the chemical, pharmaceutical and food industries as they comply with EC 10/2011, NSF/ANSI 51 food certifications. They also provide excellent dielectric and insulating properties and are not gas permeable.

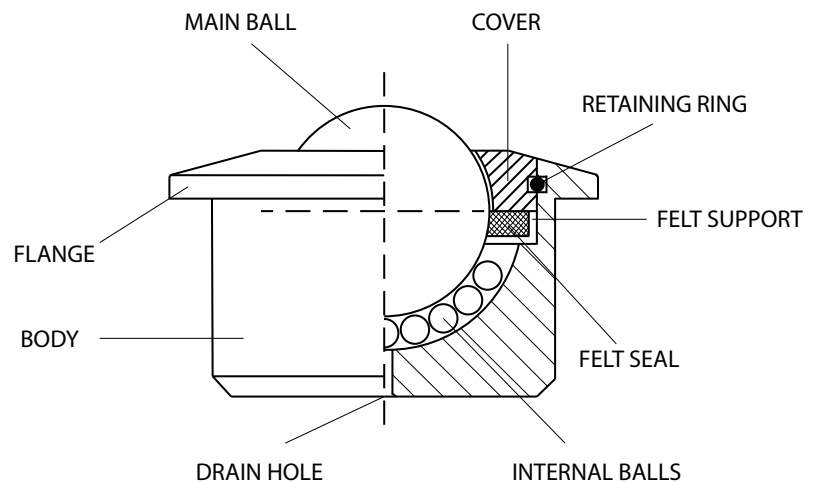

Many versions feature a felt seal that helps keep the major ball clean when rotating, thus preventing impurities from coming into contact with the recirculating balls. They usually have one or more drain holes on the bottom to facilitate the escape of impurities, liquids, condensation, etc.

They are normally supplied pre-lubricated to facilitate their conservation if not used. They do not require lubrications, even periodically applied. For particularly critical conditions of use with the presence of dirt, it is advisable to provide cleaning by applying a common release / lubricant such as WD-40.

CONDITIONS OF USE AND TECHNICAL DATA

RGPBALLS® ball transfer units can be positioned in any orientation. If the positioning is different from the conventional one (with the main ball facing upwards), we have to expect a lower performance in terms of scope and smoothness.

Some versions intended for specific applications, on the other hand, are suitable for conventional use only. Technical sheets of each version show an indication of the flow rates according to the position of use.

The temperature of use is normally included between -20 ° C to +100 ° C (+70 ° C continuously and +100 ° C intermittent). These values do not affect the correct functioning of the units. They can even reach temperatures up to +150/200 ° C by eliminating the internal dust seal.

For a high temperature use we usually suggest our version with all components made of AISI 420 stainless steel, without felt seal.

We can find the right type and calculate the extent of the load to be placed on each single unit by dividing by 3 the total weight of the load to be moved. The resulting number represents the highest weight that each unit is able to bear.

It is necessary to check that the support surface is sufficiently rigid and aligned so that all units which simultaneously support the load are subjected to the same expected stress. Likewise check that the surface of the load to be moved is rigid enough to prevent the units from plowing it. However, consider an appropriate safety margin.

To determine the distance between the units it is necessary to divide by 2.5 the horizontal side of shorter length of the load.

For example, for a slab of 700x1000 mm, the distance (D) will be 280 mm (700: 2.5). This is the space needed between one unit and the other, and it ensures that on the minimum length of the support there are enough units to support the load.

Example 1

Total load = 150 Kg

Force exerted on the spheres (F) $F = \frac{1470 \text{ N}}{3} = 490 \text{ N}$

Load on single ball = 50 KG

Example 2

Surface of the transported object = 700 × 1000 mm

Distance (D) of the spheres $D = \frac{700 \text{ mm}}{2,5} = 280 \text{ mm}$

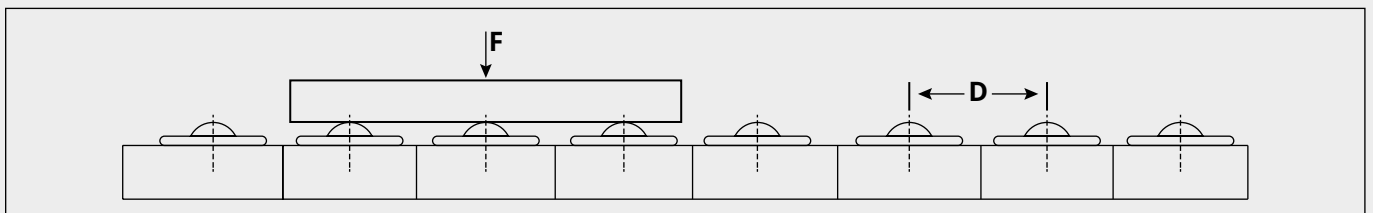

BALL TRANSFER UNITS

PAGE

“SPM” SERIES – HEAVY DUTY TYPE WITH FLANGE

11-12



Hardened machined steel housing with flange, turned steel cover, felt seal*, drain hole on the bottom. Available in steel, zinc plated steel, stainless steel. Balls in chrome steel, stainless steel AISI 420, plastic material.

* Except SPM 12, 15 and versions with plastic ball.

“SPM” SERIES – HEAVY DUTY TYPE WITH FLANGE – SEEGER GROOVE ACCORDING TO DIN 471

13



Hardened machined steel housing with flange, groove for fixing ring, turned steel cover, felt seal*, drain hole on the bottom. Available in steel, zinc plated steel, stainless steel. Balls in chrome steel, stainless steel AISI 420, plastic material.

* Except SPM 15 and versions with plastic ball.

“SBM” SERIES – HEAVY DUTY TYPE WITHOUT FLANGE

14



Hardened machined steel housing without flange, turned steel cover, felt seal*. Available in steel, zinc plated steel, stainless steel. Balls in chrome steel, stainless steel AISI420, plastic material.

* Except SBM 8, 12, 15 and versions with plastic ball.

“SPM CARGO” SERIES - FOR AIRPORT USE, DEPOSITS, FREIGHT FORWARDERS FOOTBOARDS

15



Hardened machined steel housing with flange, turned steel cover, without felt seal to ensure better smoothness and less friction. Stainless steel plate with several holes on the bottom to facilitate the escape of liquids, condensation and impurities. Available in zinc plated steel with sealing coating to increase corrosion resistance, and in stainless steel. Balls in stainless steel AISI 420.

BALL TRANSFER UNITS

PAGE

“SPM-SBM SUPER HEAVY DUTY” SERIES – FOR HIGH LOADS

16



High-performance machined, case-hardened and hardened steel housing.
Removable turned steel cover*, felt seal, drain hole on the bottom.
Available in steel, zinc plated steel, stainless steel. Balls in chrome steel and stainless steel AISI 420.

* Except SPM 60.

HEAVY-DUTY "SBM-SPM" SERIES WITH THREADED STUDS

17



Hardened machined steel housing, threaded nut machined from solid*, cover in turned steel, no felt seal to ensure better smoothness. Available in steel, zinc plated steel, stainless steel. Balls in chrome steel, 420 stainless steel, plastic material.

* Standard size M8 x 15/20 mm. Available in other sizes upon request.

HEAVY-DUTY SBM SERIES WITH INTERNAL THREADS

18



Turned, hardened steel flangeless housing
Bottom internal thread for fastening by screws or threaded rods.
Turned steel lid.
Felt gasket.*
Available in steel, galvanized steel, stainless steel.
Balls in chrome steel, AISI 420 stainless steel, plastic material.

* Except SBM 12, 15 and versions with plastic balls.

“SPM” SERIES – HEAVY DUTY TYPE WITH SPRING ELEMENT

19



External housing in turned, burnished steel. Internal unit all made of machined, hardened and zinc plated steel. Felt seal. Internal spiral spring. Available in burnished steel, stainless steel. Balls in chrome steel, AISI420 stainless steel. Fully removable.

BALL TRANSFER UNITS

PAGE

“SPP” SERIES – ALL PLASTIC MATERIAL

20-21



Housing and cover in POM (acetal resin) turned from solid, no felt seal to ensure better smoothness, drain hole on the bottom.
Plastic or AISI316 stainless steel balls.

“SPS” SERIES – LIGHT DUTY TYPE

22



Zinc plated pressed metal sheet metal housing and cover*, inner shell in hardened pressed steel*, felt seal**.
Balls in chrome steel, AISI420 stainless steel, plastic material.

* Available completely in stainless steel version.

** Except SPS 15 and versions with plastic ball.

“SPS DV” TYPE IN PRESSED METAL SHEET WITH FIXING HOLES

23



Housing in hardened and zinc plated pressed metal sheet.
Holes on the flange for fixing by means of screws or rivets.
Without felt sealing system to guarantee a better fluency.
Balls made of chrome steel, AISI 420C stainless steel, plastic material.



Made in Italy - All products shown in this catalogue are *Made in Italy*.

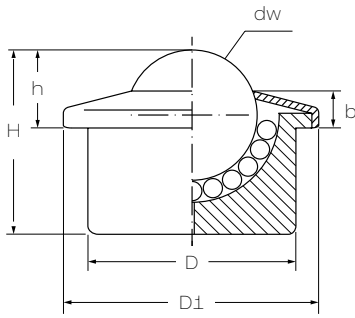

SPM 12

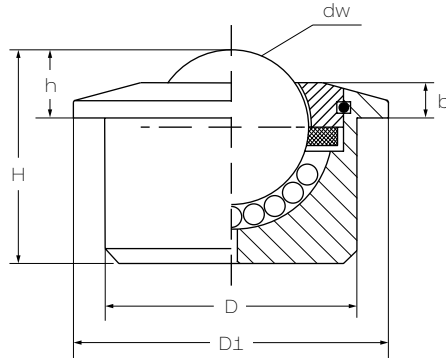

SPM 15/22/25

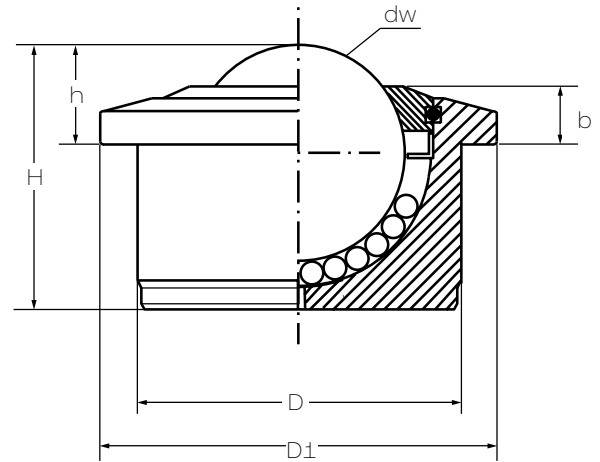

SPM 30/45

- Hardened housing with flange machined from bar, in order to guarantee high flow rates and a greater resistance to stress.
- Reinforced cover in turned steel.
- Felt seal (except for SPM 12 and 15).
- Drain hole on the bottom.

ITEM	TYPE	VERSION	DIMENSIONS						LOAD (Kg)		WEIGHT (Kg)
			dw	D	D1	h	H	b			
SPM01200A	SPM 12 A	Steel housing, balls made of chrome steel	12	22	27	8	16,75	5	25	15	0,035
SPM01500A	SPM 15 A		15	24	31	9,5	21	5	60	35	0,060
SPM02200A	SPM 22 A		22	36	45	9,8	30,5	5,5	180	125	0,185
SPM02500A	SPM 25 A		25	38	46	13	30,5	8,5	200	140	0,195
SPM03000A	SPM 30 A		30	45	55	13,8	36,8	8,5	350	250	0,355
SPM04500A	SPM 45 A		45	62	75	19	53,5	10,5	600	420	0,990
SPM01200B	SPM 12 B	Zinc plated steel housing, balls made of chrome steel	12	22	27	8	16,75	5	25	15	0,035
SPM01500B	SPM 15 B		15	24	31	9,5	21	5	60	35	0,060
SPM02200B	SPM 22 B		22	36	45	9,8	30,5	5,5	180	125	0,185
SPM02500B	SPM 25 B		25	38	46	13	30,5	8,5	200	140	0,195
SPM03000B	SPM 30 B		30	45	55	13,8	36,8	8,5	350	250	0,355
SPM04500B	SPM 45 B		45	62	75	19	53,5	10,5	600	420	0,990
SPM01200C	SPM 12 C	Zinc plated steel housing, balls made of stainless steel AISI 420	12	22	27	8	16,75	5	25	10	0,035
SPM01500C	SPM 15 C		15	24	31	9,5	21	5	60	25	0,060
SPM02200C	SPM 22 C		22	36	45	9,8	30,5	5,5	180	90	0,185
SPM02500C	SPM 25 C		25	38	46	13	30,5	8,5	140	100	0,195
SPM03000C	SPM 30 C		30	45	55	13,8	36,8	8,5	350	170	0,355
SPM04500C	SPM 45 C		45	62	75	19	53,5	10,5	600	280	0,990
SPM01200SS	SPM 12 SS	Housing and internal parts in stainless steel AISI 420, balls in stainless steel AISI 420	12	22	27	8	16,75	5	20	10	0,035
SPM01500SS	SPM 15 SS		15	24	31	9,5	21	5	40	25	0,060
SPM02200SS	SPM 22 SS		22	36	45	9,8	30,5	5,5	130	90	0,185
SPM02500SS	SPM 25 SS		25	38	46	13	30,5	8,5	140	100	0,195
SPM03000SS	SPM 30 SS		30	45	55	13,8	36,8	8,5	220	170	0,355
SPM04500SS	SPM 45 SS		45	62	75	19	53,5	10,5	350	280	0,990

"SPM" SERIES – HEAVY DUTY TYPE WITH FLANGE AND MAIN PLASTIC BALL

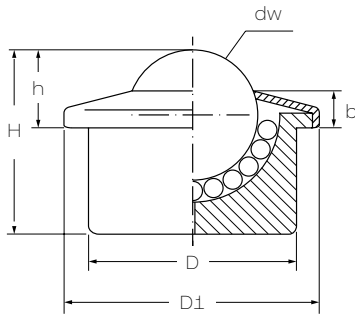

SPM 12

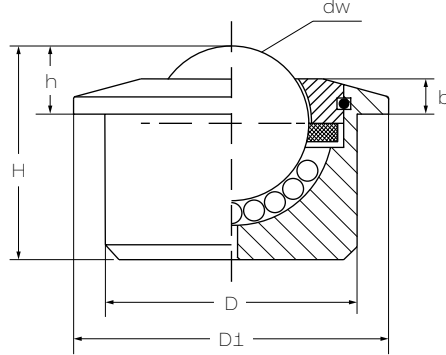

SPM 15/22/25

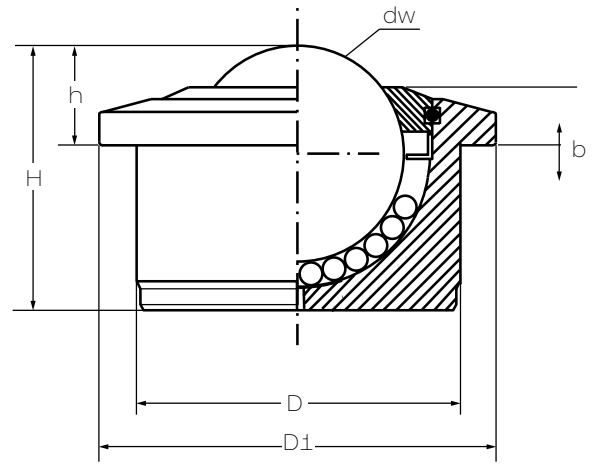

SPM 30/45

- Hardened housing with flange machined from bar, in order to guarantee high flow rates and a greater resistance to stress.
- Reinforced cover in turned steel.
- Drain hole on the bottom.
- Versions with main plastic ball:
 - best choice for handling particularly delicate surfaces such as sheets of glass or crystal, wooden panels, painted or satin sheet plates, and so on*
 - felt seal to ensure maximum smoothness even in the presence of light loads
 - usually not to be used turned upside down*
 - working temperature 0°/60°*

ITEM	TYPE	VERSION	DIMENSIONS						LOAD (Kg)		WEIGHT (Kg)
			dw	D	D1	h	H	b			
SPM01200BD	SPM 12 BD	Zinc plated steel body, small chrome steel balls, main ball made of plastic*	12	22	27	8	16,75	5	5	-	0,030
SPM01500BD	SPM 15 BD		15	24	31	9,5	21	5	13	-	0,046
SPM02200BD	SPM 22 BD		22	36	45	9,8	30,5	5,5	20	-	0,150
SPM02500BD	SPM 25 BD		25	38	46	13	30,5	8,5	23	-	0,135
SPM03000BD	SPM 30 BD		30	45	55	13,8	36,8	8,5	25	-	0,240
SPM04500BD	SPM 45 BD		45	62	75	19	53,5	10,5	30	-	0,670
SPM01200CD	SPM 12 CD	Zinc plated steel body, small AISI 420 stainless steel balls, main ball made of plastic*	12	22	27	8	16,75	5	5	-	0,030
SPM01500CD	SPM 15 CD		15	24	31	9,5	21	5	13	-	0,046
SPM02200CD	SPM 22 CD		22	36	45	9,8	30,5	5,5	20	-	0,150
SPM02500CD	SPM 25 CD		25	38	46	13	30,5	8,5	23	-	0,135
SPM03000CD	SPM 30 CD		30	45	55	13,8	36,8	8,5	25	-	0,240
SPM04500CD	SPM 45 CD		45	62	75	19	53,5	10,5	30	-	0,670
SPM01200SSCD	SPM 12 SSCD	Housing and internal parts in stainless steel, small balls in stainless steel AISI 420, main ball in plastic*	12	22	27	8	16,75	5	5	-	0,030
SPM01500SSCD	SPM 15 SSCD		15	24	31	9,5	21	5	13	-	0,046
SPM02200SSCD	SPM 22 SSCD		22	36	45	9,8	30,5	5,5	20	-	0,150
SPM02500SSCD	SPM 25 SSCD		25	38	46	13	30,5	8,5	23	-	0,135
SPM03000SSCD	SPM 30 SSCD		30	45	55	13,8	36,8	8,5	25	-	0,240
SPM04500SSCD	SPM 45 SSCD		45	62	75	19	53,5	10,5	30	-	0,670

“SPM” SERIES – HEAVY DUTY TYPE WITH FLANGE – SEEGER GROOVE ACCORDING TO DIN 471

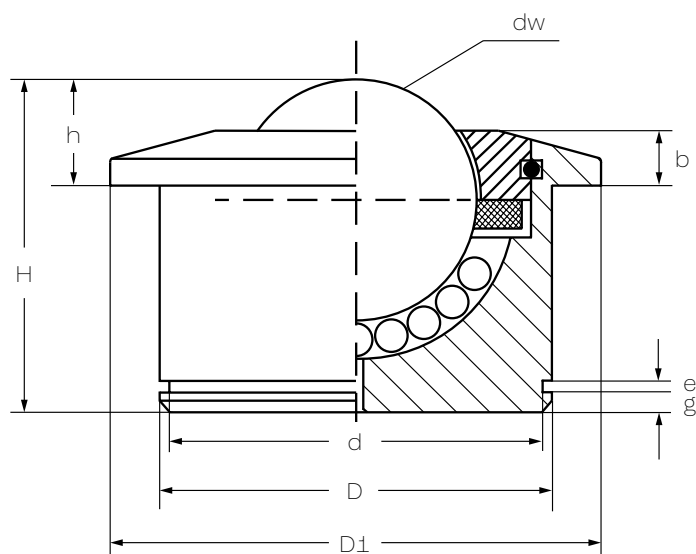

TYPE	g	d	e
SPM 15	2	22,8 +0,1/-0,2	1,3 +/-0,2
SPM 22	3	34 +0 -0,25	1,90 +/-0,2
SPM 30	4	42,00 +0 -0,25	1,90 +/-0,2
SPM 45	4,5	59 +0 -0,3	2,15 +/-0,2

- Hardened housing with flange machined from bar, in order to guarantee high flow rates and a greater resistance to stress.
- Seeger groove on the housing for the insertion of fixing rings according to DIN 471 standards*
- Reinforced cover in turned steel.
- Felt seal (except for SPM 15).
- Drain hole on the bottom.
- All listed versions can also be produced with main plastic ball

* Groove can be made on request with different dimensions and heights.

ITEM	TYPE	VERSION	DIMENSIONS						LOAD (Kg)		WEIGHT (Kg)
			dw	D	D1	h	H	b			
SPM01500AR	SPM 15 A-R	Steel housing, balls made of chrome steel	15	24	31	9,5	21	5	60	35	0,060
SPM02200AR	SPM 22 A-R		22	36	45	9,8	30,5	5,5	180	125	0,185
SPM03000AR	SPM 30 A-R		30	45	55	13,8	36,8	8,5	350	250	0,355
SPM04500AR	SPM 45 A-R		45	62	75	19	53,5	10,5	600	420	0,990
SPM01500BR	SPM 15 B-R	Zinc plated steel housing, balls made of chrome steel	15	24	31	9,5	21	5	60	35	0,060
SPM02200BR	SPM 22 B-R		22	36	45	9,8	30,5	5,5	180	125	0,185
SPM03000BR	SPM 30 B-R		30	45	55	13,8	36,8	8,5	350	250	0,355
SPM04500BR	SPM 45 B-R		45	62	75	19	53,5	10,5	600	420	0,990
SPM01500CR	SPM 15 C-R	Zinc plated steel housing, balls made of stainless steel AISI 420	15	24	31	9,5	21	5	60	25	0,060
SPM02200CR	SPM 22 C-R		22	36	45	9,8	30,5	5,5	180	90	0,185
SPM03000CR	SPM 30 C-R		30	45	55	13,8	36,8	8,5	350	170	0,355
SPM04500CR	SPM 45 C-R		45	62	75	19	53,5	10,5	600	280	0,990
SPM01500SSR	SPM 15SS-R	Housing and internal parts in stainless steel, balls in stainless steel AISI 420	15	24	31	9,5	21	5	40	25	0,060
SPM02200SSR	SPM 22SS-R		22	36	45	9,8	30,5	5,5	130	90	0,185
SPM03000SSR	SPM 30SS-R		30	45	55	13,8	36,8	8,5	240	170	0,355
SPM04500SSR	SPM 45SS-R		45	62	75	19	53,5	10,5	400	280	0,990

“SBM” SERIES – HEAVY DUTY TYPE WITHOUT FLANGE

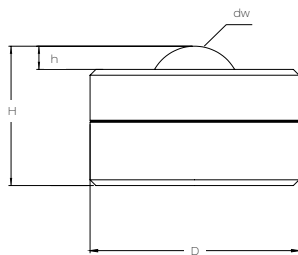

SBM 8

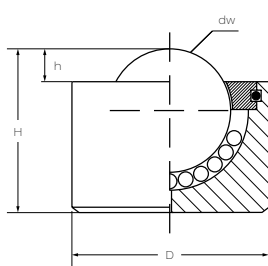

SBM 12

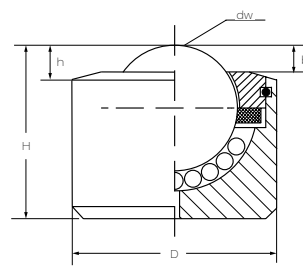

SBM 15/22/30/45



- Hardened machined steel housing without flange.
- Turned steel cover.
- To be used in applications which require to minimize the protrusion from the housing seat.
In order to ensure good smoothness even under limited loads, SBM 12, 15 and all versions with main plastic ball are assembled without felt seal.
- Drain hole on the bottom.
- Working temperature for main plastic ball versions: 0°/60°*

ITEM	TYPE	VERSION	DIMENSIONS					LOAD (Kg)		WEIGHT (Kg)
			dw	D	h	H	b			
SBM00800A	SBM 8 A*	Steel housing, balls made of chrome steel	8	18	2	12	-	12	9	0,018
SBM01200A	SBM 12 A		12	22	3,8	17,5	-	25	15	0,035
SBM00800B	SBM 8 B*	Zinc plated steel housing, balls made of chrome steel	8	18	2	12	-	12	9	0,018
SBM01200B	SBM 12 B		12	22	3,8	17,5	-	25	15	0,035
SBM01500B	SBM 15 B		15	24	5	20,9	4,6	60	35	0,050
SBM02200B	SBM 22 B		22	36	5,8	30,5	4,5	180	125	0,170
SBM03000B	SBM 30 B		30	45	8	36,8	5	350	250	0,330
SBM04500B	SBM 45 B		45	62	12	53,5	8	600	420	0,945
SBM00800C	SBM 8 C	Zinc plated steel housing, balls made of stainless steel AISI 420	8	18	2	12	-	10	7	0,018
SBM01200C	SBM 12 C		12	22	3,8	17,5	-	25	10	0,035
SBM01500C	SBM 15 C		15	24	5	20,9	4,6	60	25	0,050
SBM02200C	SBM 22 C		22	36	5,8	30,5	4,5	180	90	0,170
SBM03000C	SBM 30 C		30	45	8	36,8	5	350	170	0,330
SBM04500C	SBM 45 C		45	62	12	53,5	8	600	280	0,945
SBM01200SS	SBM 12 SS	Housing and internal parts in stainless steel, balls in stainless steel AISI 420	12	22	3,8	17,5	-	20	10	0,035
SBM01500SS	SBM 15 SS		15	24	5	20,9	4,6	40	25	0,050
SBM00800BD	SBM 8 BD	Zinc plated steel housing, main plastic ball, small balls in chrome steel	8	18	2	12	-	3	-	0,016
SBM01200BD	SBM 12 BD		12	22	3,8	17,5	-	5	-	0,030
SBM01500BD	SBM 15 BD		15	24	5	20,9	4,6	13	-	0,035
SBM02200BD	SBM 22 BD		22	36	5,8	30,5	4,5	20	-	0,140
SBM03000BD	SBM 30 BD		30	45	8	36,8	5	25	-	0,240
SBM04500BD	SBM 45 BD		45	62	12	53,5	8	30	-	0,650
SBM00800CD	SBM 8 CD	Zinc plated steel housing, main plastic ball, small balls in stainless steel AISI 420	8	18	2	12	-	3	-	0,016
SBM01200CD	SBM 12 CD		12	22	3,8	17,5	-	5	-	0,030
SBM01500CD	SBM 15 CD		15	24	5	20,9	4,6	13	-	0,035
SBM02200CD	SBM 22 CD		22	36	5,8	30,5	4,5	20	-	0,140
SBM03000CD	SBM 30 CD		30	45	8	36,8	5	25	-	0,240
SBM04500CD	SBM 45 CD		45	62	12	53,5	8	30	-	0,650
SBM01200SSCD	SBM12SSCD	Housing and internal parts in stainless steel, small balls in stainless steel AISI 420, main ball in plastic*	12	22	3,8	17,5	-	5	-	0,030
SBM01500SSCD	SBM15SSCD		15	24	5	20,9	4,6	13	-	0,035

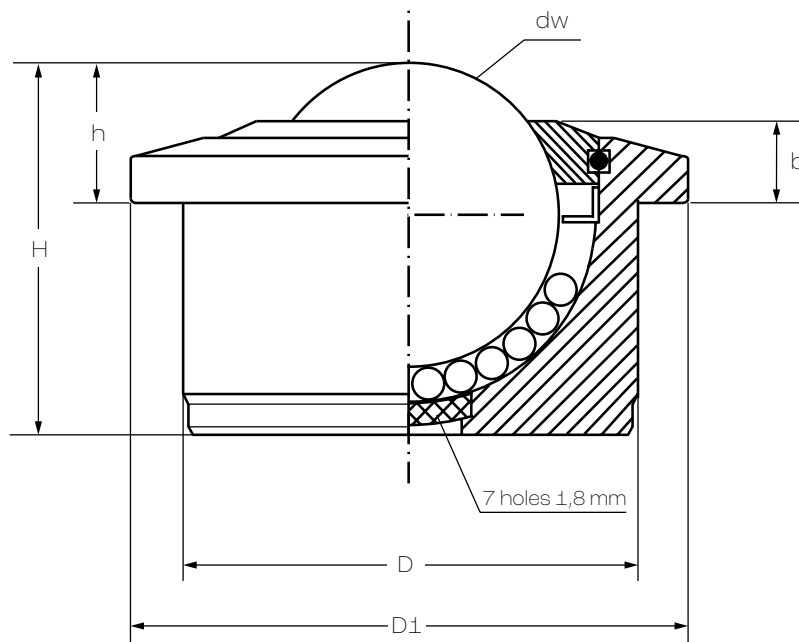
“SPM CARGO” SERIES - FOR AIRPORT USE, DEPOSITS, FREIGHT FORWARDERS FOOTBOARDS





- Hardened housing with flange machined from bar, in order to guarantee high flow rates and a greater resistance to stress.
- Particularly suitable for use in airport systems, depots, platforms for shippers ecc.
- Trivalent zinc plating to offer greater resistance to corrosion.
- Reinforced cover in turned steel.
- No felt seal, in order to offer maximum smoothness in all conditions of use.
- Stainless steel disc with 7 drain holes on the bottom to facilitate the escape of condensate, dust, impurities.

ITEM	TYPE	VERSION	DIMENSIONS						LOAD (Kg)		WEIGHT (Kg)
			dw	D	D1	h	H	b			
SPM03000C-G	SPM 30 C Cargo	Zinc plated steel housing (with sealing coating), balls made of stainless steel AISI 420	30	45	55	13,8	36,8	8,5	350	240	0,355
SPM04500C-G	SPM 45 C Cargo		45	62	75	19	53,5	10,5	600	420	0,990
SPM03000SS-G	SPM 30 SS Cargo	Housing and internal parts in stainless steel, balls in stainless steel AISI 420	30	45	55	13,8	36,8	8,5	240	170	0,355
SPM04500SS-G	SPM 45 SS Cargo		45	62	75	19	53,5	10,5	400	280	0,990

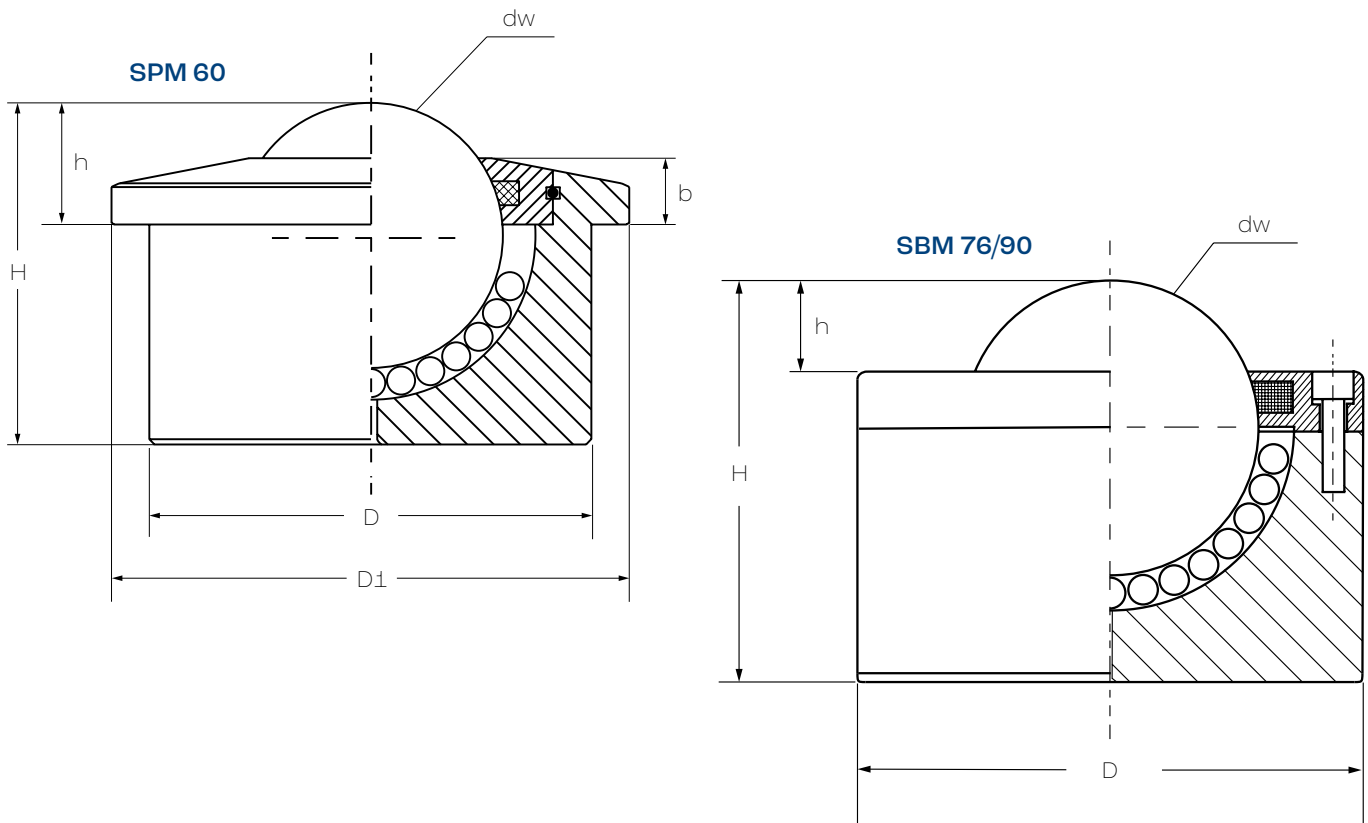
“SPM-SBM SUPER HEAVY DUTY” SERIES – FOR HIGH LOADS



- High-performance machined, case-hardened and hardened steel housing.
- It can withstand high loads and features greater resistance to stress.
- Reinforced cover in turned steel (can be removed for maintenance, except for SPM 60).
- Felt seal.
- Drain hole on the bottom.

ITEM	TYPE	VERSION	DIMENSIONS*						LOAD (Kg)		WEIGHT (Kg)
			dw	D	D1	h	H	b			
SPM06000A	SPM 60 A	Steel housing, balls made of chrome steel	60	100	117	30	77,5	16	1500	900	4
SBM07600A	SBM 76 A		76	130	-	23	103	-	2500	1500	10
SBM09000A	SBM 90 A		90	145	-	25	115	-	3000	2000	11,250
SPM06000B	SPM 60 B	Zinc plated steel housing, balls made of chrome steel	60	100	117	30	77,5	16	1500	900	4
SBM07600B	SBM 76 B		76	130	-	23	103	-	2500	1500	10
SBM09000B	SBM 90 B		90	145	-	25	115	-	3000	2000	11,250
SPM06000C	SPM 60 C	Zinc plated steel housing, balls made of stainless steel AISI 420	60	100	117	30	77,5	16	1000	600	4
SBM07600C	SBM 76 C		76	130	-	23	103	-	2000	900	10
SBM09000C	SBM 90 C		90	145	-	25	115	-	2500	1200	11,250
SPM06000SS	SPM 60 SS	Housing and internal parts in stainless steel, balls made of stainless steel AISI 420	60	100	117	30	77,5	16	900	600	4
SBM07600SS	SBM 76 SS		76	130	-	23	103	-	1500	900	10
SBM09000SS	SBM 90 SS		90	145	-	25	115	-	1800	1200	11,250

* Height Tolerance +/- 0,4 mm

* Diameter Tolerance +/- 0,3 mm

“SPM-SBM” SERIES – HEAVY DUTY TYPE WITH THREADED NUT

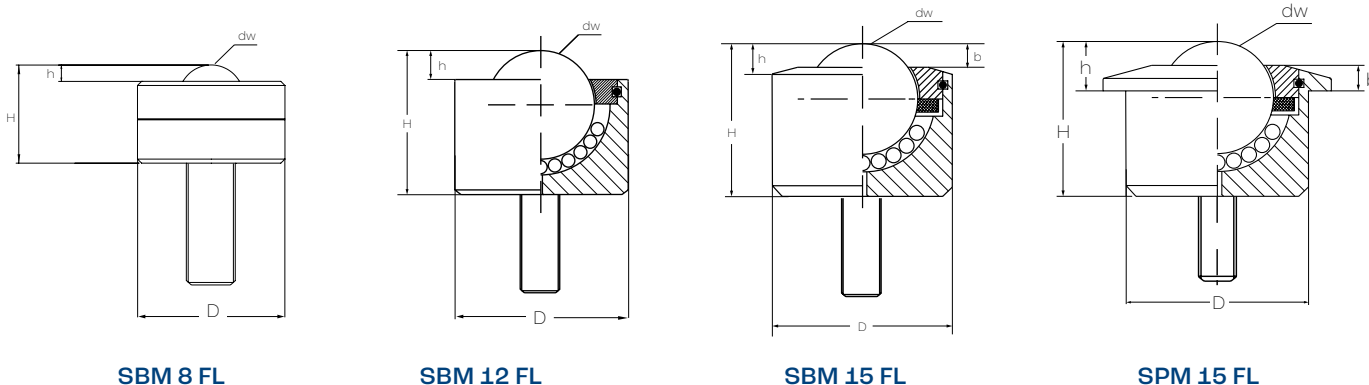

- Hardened housing machined from bar.
- Threaded nut machined from solid (available in different diameters / lengths).
- No felt seal to ensure better smoothness even with low loads.
- Versions with main plastic ball:
 - best choice for handling particularly delicate surfaces such as sheets of glass or crystal, wooden panels, painted or satin sheet plates, and so on*
 - usually not to be used turned upside down*
 - working temperature 0°/60°*

ITEM	TYPE	VERSION	DIMENSIONS						LOAD (Kg)		WEIGHT (Kg)
			dw	D	D1	h	H	b			
SBM008FLE6X15B	SBM 8 B FL	Zinc plated steel housing, balls made of chrome steel	8	18	-	2	12	-	12	9	0,025
SBM012FLE8X15B	SBM 12 B FL		12	22	-	3,8	17,5	-	25	15	0,045
SBM015FLE8X15B	SBM 15 B FL		15	24	-	5	21	4,6	60	35	0,060
SPM015FLE8X15B	SPM 15 B FL		15	24	31	9,5	21	5	60	35	0,070
SBM008FLE6X15C	SBM 8 C FL	Zinc plated steel housing, balls made of stainless steel AISI 420	8	18	-	2	12	-	10	7	0,025
SBM012FLE8X15C	SBM 12 C FL		12	22	-	3,8	17,5	-	25	10	0,045
SBM015FLE8X15C	SBM 15 C FL		15	24	-	5	21	4,6	60	35	0,060
SPM015FLE8X15C	SPM 15 C FL		15	24	31	9,5	21	5	60	25	0,070
SBM012FLE8X15SS	SBM 12 SS FL	Housing and internal parts in stainless steel, balls in stainless steel AISI 420	12	22	-	3,8	17,5	-	20	10	0,045
SBM015FLE8X15SS	SBM 15 SS FL		15	24	-	5	21	4,6	40	35	0,060
SPM015FLE8X15SS	SPM 15 SS FL		15	24	31	9,5	21	5	40	25	0,070
SBM008FLE6X15BD	SBM 8 BD FL	Zinc plated steel housing, main plastic ball, small balls in chrome steel	8	18	-	2	12	-	3	-	0,020
SBM012FLE8X15BD	SBM 12 BD FL		12	22	-	3,8	17,5	-	5	-	0,035
SBM015FLE8X15BD	SBM 15 BD FL		15	24	-	5	21	4,6	13	-	0,060
SPM015FLE8X15BD	SPM 15 BD FL		15	24	31	9,5	21	5	13	-	0,055
SBM008FLE6X15CD	SBM 8 CD FL	Zinc plated steel housing, main plastic ball, small balls in stainless steel AISI 420	8	18	-	2	12	-	3	-	0,020
SBM012FLE8X15CD	SBM 12 CD FL		12	22	-	3,8	17,5	-	5	-	0,035
SBM015FLE8X15CD	SBM 15 CD FL		15	24	-	5	21	4,6	13	-	0,060
SPM015FLE8X15CD	SPM 15 CD FL		15	24	31	9,5	21	5	13	-	0,055
SBM012FLE8X15SS-CD	SBM 12 SS CD FL	Housing and internal parts in stainless steel, small balls in stainless steel AISI 420, main ball in plastic*	12	22	-	3,8	17,5	-	5	-	0,035
SBM015FLE8X15SS-CD	SBM 15 SS CD FL		15	24	-	5	21	4,6	13	-	0,060
SPM015FLE8X15SS-CD	SPM 15 SS CD FL		15	24	31	9,5	21	5	13	-	0,055

“SPM-SBM” SERIES – HEAVY DUTY TYPE WITH INTERNAL THREAD

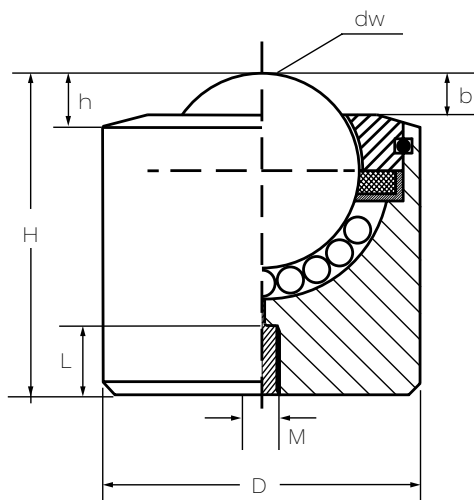

- Hardened machined steel housing without flange.
- Turned steel cover.
- To be used in applications which require to minimize the protrusion from the housing seat.
- In order to ensure good smoothness even under limited loads, SBM 12, 15 and all versions with main plastic ball are assembled without felt seal.
- The threaded hole at the bottom allows a strong fixing in all conditions of use.
- Working temperature for main plastic ball versions: 0°/60°*

ITEM	TYPE	VERSION	DIMENSIONS							LOAD (Kg)		WEIGHT (Kg)
			dw	D	h	H	b	M	L			
SBM015FLI8X8B	SBM 15 B FL int.	Zinc plated steel housing, balls made of chrome steel	15	24	5,5	28	4,8	8	8	60	35	0,075
SBM022FLI8X10B	SBM 22 B FL int.		22	36	5,8	40,5	4,5	8	10	180	125	0,260
SBM030FLI8X10B	SBM 30 B FL int.		30	45	8	46,8	6	8	10	350	250	0,460
SBM045FLI8X10B	SBM 45 B FL int.		45	62	13	63,5	10	8	10	600	420	1,190
SBM015FLI8X8C	SBM 15 C FL int.	Zinc plated steel housing, balls made of stainless steel AISI 420	15	24	5,5	28	4,8	8	8	60	25	0,075
SBM022FLI8X10C	SBM 22 C FL int.		22	36	5,8	40,5	4,5	8	10	180	90	0,260
SBM030FLI8X10C	SBM 30 C FL int.		30	45	8	46,8	6	8	10	350	170	0,460
SBM045FLI8X10C	SBM 45 C FL int.		45	62	13	63,5	10	8	10	600	280	1,190
SBM015FLI8X8BD	SBM 15 BD FL int.	Zinc plated steel housing, main plastic ball, small balls in chrome steel	15	24	5,5	28	4,8	8	8	13	-	0,060
SBM022FLI8X10BD	SBM 22 BD FL int.		22	36	5,8	40,5	4,5	8	10	20	-	0,220
SBM030FLI8X10BD	SBM 30 BD FL int.		30	45	8	46,8	6	8	10	25	-	0,360
SBM045FLI8X10BD	SBM 45 BD FL int.		45	62	13	63,5	10	8	10	30	-	0,890
SBM015FLI8X8CD	SBM 15 CD FL int.	Zinc plated steel housing, main plastic ball, small balls made of stainless steel AISI 420	15	24	5,5	24	4,8	8	8	13	-	0,060
SBM022FLI8X10CD	SBM 22 CD FL int.		22	36	5,8	40,5	4,5	8	10	20	-	0,220
SBM030FLI8X10CD	SBM 30 CD FL int.		30	45	8	46,8	6	8	10	25	-	0,360
SBM045FLI8X10CD	SBM 45 CD FL int.		45	62	11,5	63,5	8,5	8	10	30	-	0,890

“SPM” SERIES – HEAVY DUTY TYPE WITH SPRING ELEMENT

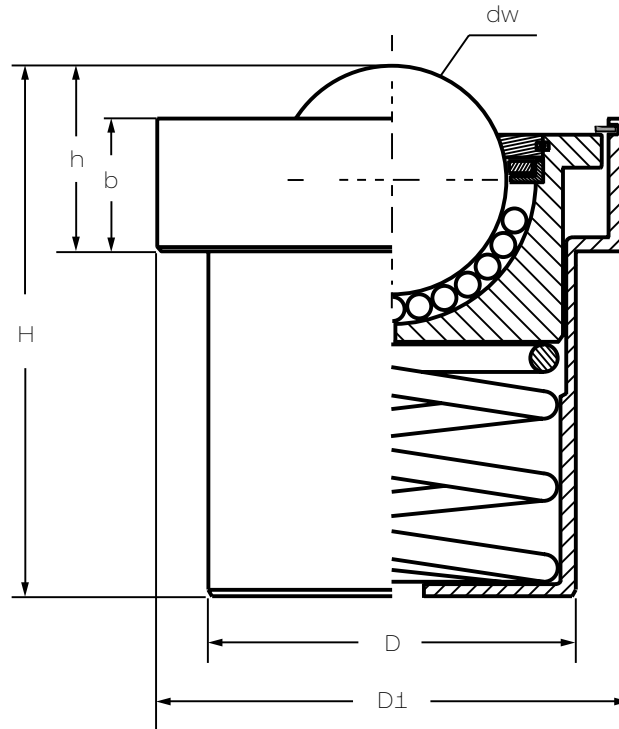

- External housing in turned, burnished steel
- It guarantees solidity and maintains its features over time, avoiding the typical bending of the pressed metal sheet.
- Internal unit all made of machined, hardened and zinc plated steel.
- Felt seal and drain hole on the bottom.
- Hardened and ground internal spiral spring.
- The fixing ring provided to lock the ball transfer unit can be removed for any maintenance and / or replacement of the internal spring.

ITEM	TYPE	VERSION	DIMENSIONS						STROKE mm	DYNAMIC LOAD Kg.	MAXIMUM STATIC LOAD*		WEIGHT (Kg)
			dw	D	D1	h	H	b				Kg.	
SPM02200AF	SPM 22 AF	Burnished steel external housing, internal unit made of zinc plated steel, balls made of chrome steel	22	39	50	18,6	58	14	4,6	75	80	0,36	
SPM03000AF	SPM 30 AF		30	48,5	62	24,5	70	17,5	7	135	240	0,68	
SPM04500AF	SPM 45 AF		45	66,5	85	36,5	100,5	25,5	11	230	350	1,90	
SPM02200CF	SPM 22 CF	Burnished steel external housing, internal unit made of zinc plated steel, balls made of stainless steel AISI 420	22	39	50	18,6	58	14	4,6	75	80	0,36	
SPM03000CF	SPM 30 CF		30	48,5	62	24,5	70	17,5	7	135	240	0,68	
SPM04500CF	SPM 45 CF		45	66,5	85	36,5	100,5	25,5	11	230	350	1,90	

* Attention: the maximum static load indicates the complete compression of the ball

“SPP” SERIES – ALL PLASTIC MATERIAL

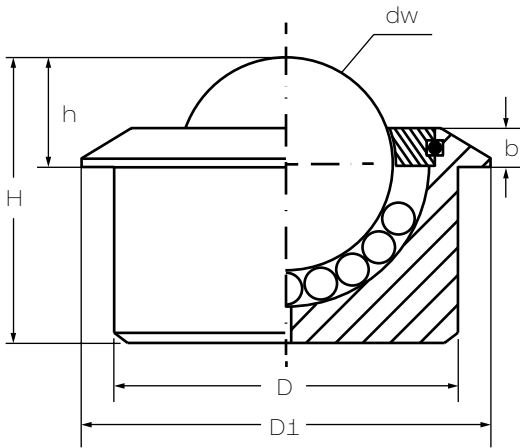

SPP 15

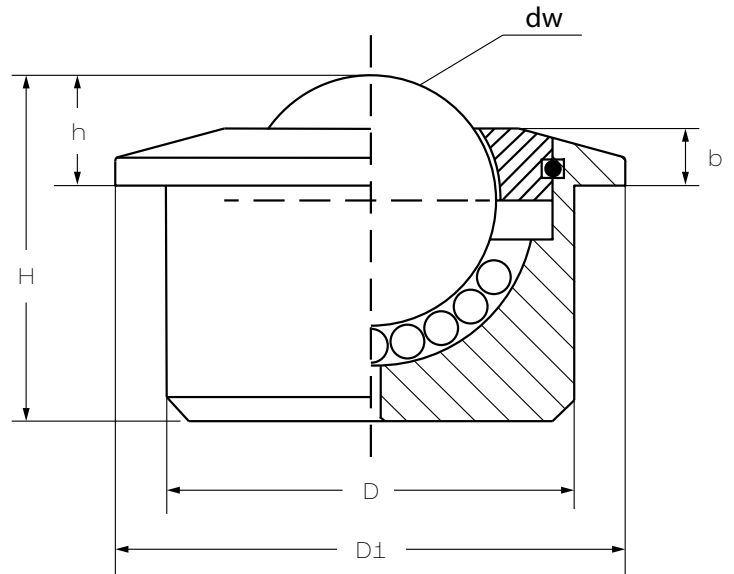

SPP 22/30/45

- Housing with flange all made of POM (acetal resin) turned from solid.
- No felt seal, in order to ensure better smoothness even with low loads and to prevent liquids absorption.
- Drain hole on the bottom.
- Salt water and chemicals-resistant.
- Non-magnetic, they do not conduct electricity.
- Suitable for chemical, pharmaceutical, medical applications and so on.
- All listed versions can also be produced with a groove for inserting a fixing ring according to DIN 471.
- Working temperature 0°/60°.

ITEM	TYPE	VERSION	DIMENSIONS						LOAD	WEIGHT (Kg)
			dw	D	D1	h	H	b		
SPP01500PC	SPP 15 PC	Housing made of POM acetal resin, all balls made of stainless steel AISI 316	15	24	30	8	20	3	7	0,024
SPP02200PC	SPP 22 PC		22	36	45	9,8	30,5	5,5	10	0,074
SPP03000PC	SPP 30 PC		30	45	55	13,8	36,8	8	15	0,162
SPP04500PC	SPP 45 PC		45	62	75	19	53,5	10	20	0,502
SPP01500PCD	SPP15 PCD	Housing and main ball made of POM acetal resin, small balls made of stainless steel AISI 316	15	24	30	8	20	3	7	0,015
SPP02200PCD	SPP 22 PCD		22	36	45	9,8	30,5	5,5	10	0,040
SPP03000PCD	SPP 30 PCD		30	45	55	13,8	36,8	8	15	0,070
SPP04500PCD	SPP 45 PCD		45	62	75	19	53,5	10	20	0,185
SPP01500PD	SPP 15 PD	Housing and all balls made of POM acetal resin	15	24	30	8	20	3	7	0,012
SPP02200PD	SPP 22 PD		22	36	45	9,8	30,5	5,5	10	0,036
SPP03000PD	SPP 30 PD		30	45	55	13,8	36,8	8	15	0,066
SPP04500PD	SPP 45 PD		45	62	75	19	53,5	10	20	0,176

STRENGTHS OF THE MATERIAL USED

- High resistance to stress and efforts over time.
- Excellent dimensional stability.
- Low friction coefficient.
- High compressive strength and impact resistance even at low temperatures.
- High chemical resistance to solvents, fuels and strong alkalis; high resistance to thermal and oxidative degradation.
- Excellent workability on machine tools, it is often used for automatic machines.
- Food certifications EC 10/2011, NSF/ANSI 51, even when colored.
- Good dielectric and insulating properties.
- Not permeable to gases, no microporosity.
- Natural white color; on request also red, blue, green, yellow, orange.

SIGNIFICANT ASPECTS

- It has a lower abrasion resistance compared to PA6, especially in dirty and dusty environments.
- It does not resist to concentrated acids.

Please note: all versions can be provided without flange (see SBM drawing hereunder)

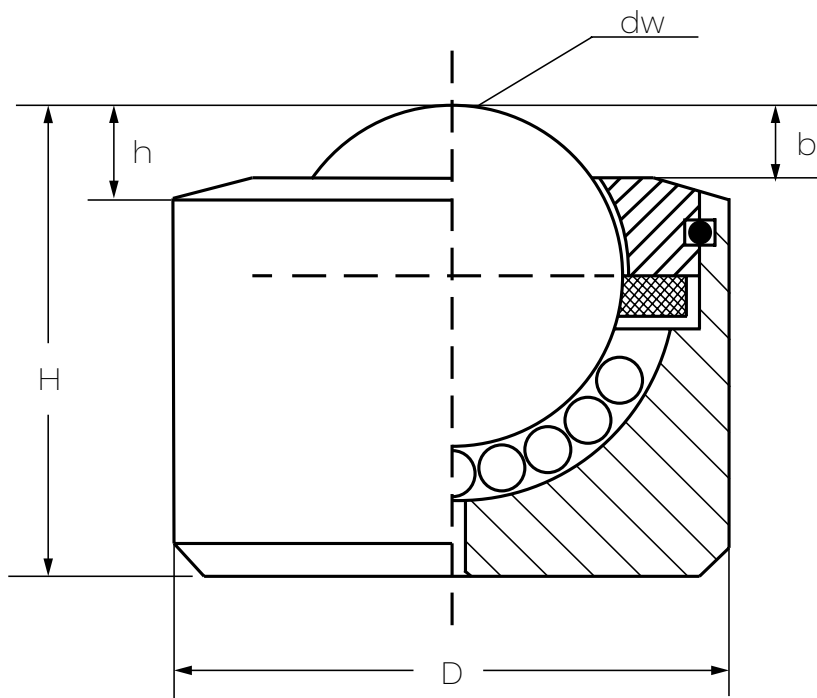

"SPS" SERIES – LIGHT DUTY TYPE

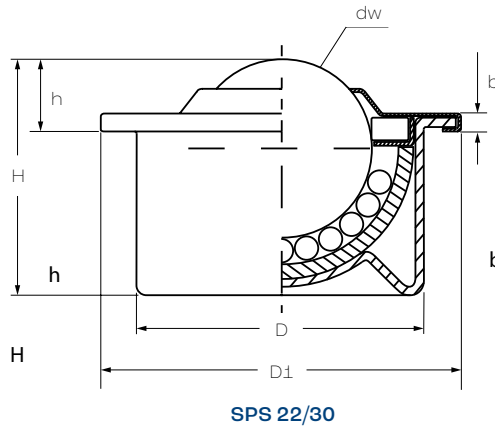
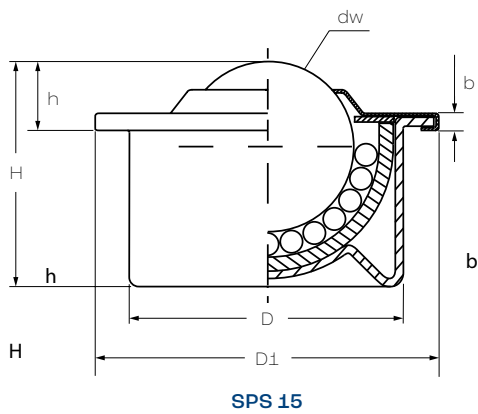

- Dimensionally interchangeable with the SPM version, they guarantee good smoothness and greater lightness at low costs.
- Housing and cover in pressed metal sheet.
- Inner shell in hardened pressed steel.
- Felt seal (except for SPS 12 and 15).
- Versions with main plastic ball:
 - Best choice for handling particularly delicate surfaces such as sheets of glass or crystal, wooden panels, painted or satin sheet plates, and so on;*
 - No felt seal to ensure better smoothness even with low loads;*
 - Usually not to be used turned upside down.*

ITEM	TYPE	VERSION	DIMENSIONS**						LOAD (Kg)		WEIGHT (Kg)
			dw	D	D1	h	H	b			
SPS01500B	SPS 15 B	Balls made of chrome steel	15	24	31	9,5	21	3	50	35	0,037
SPS02200B	SPS 22 B		22	36	45	9,8	29,5	3,5	150	80	0,130
SPS03000B	SPS 30 B		30	45	55	13,8	37,8	4	250	170	0,265
SPS01500C	SPS 15 C	Balls made of stainless steel AISI 420	15	24	31	9,5	21	3	50	25	0,037
SPS02200C	SPS 22 C		22	36	45	9,8	29,5	3,5	150	60	0,130
SPS03000C	SPS 30 C		30	45	55	13,8	37,8	4	250	100	0,265
SPS01500SS	SPS 15 SS	Housing and internal parts in stainless steel, balls in stainless steel AISI 420	15	24	31	9,5	21	3	35	25	0,037
SPS02200SS	SPS 22 SS		22	36	45	9,8	29,5	3,5	90	60	0,130
SPS01500BD	SPS 15 BD	Main plastic ball* and small balls in chrome steel	15	24	31	9,5	21	3	13	-	0,026
SPS02200BD	SPS 22 BD		22	36	45	9,8	29,5	3,5	20	-	0,084
SPS03000BD	SPS 30 BD		30	45	55	13,8	37,8	4	25	-	0,155
SPS01500CD	SPS 15 CD	Main plastic ball* and small balls in stainless steel AISI 420	15	24	31	9,5	21	3	13	-	0,026
SPS02200CD	SPS 22 CD		22	36	45	9,8	29,5	3,5	20	-	0,084
SPS03000CD	SPS 30 CD		30	45	55	13,8	37,8	4	25	-	0,155
SPS0150SSCD	SPS15SSCD	Housing and internal parts in stainless steel, small balls in stainless steel AISI 420, main ball in plastic*	15	24	31	9,5	21	3	13	-	0,026
SPS02200SSCD	SPS22SSCD		22	36	45	9,8	29,5	3,5	20	-	0,084

** Height Tolerance +/- 0,4 mm
 ** Diameter Tolerance +/- 0,4 mm

“SPS DV” PRESSED METAL SHEET TYPE WITH FIXING HOLES

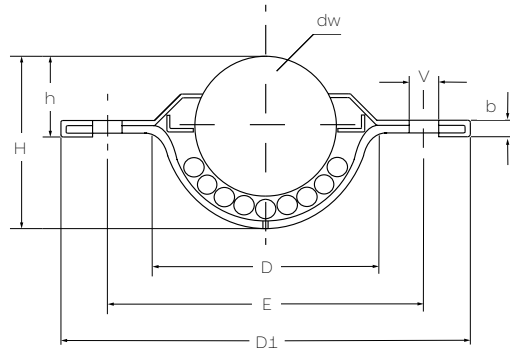

- Housing in hardened and zinc plated pressed metal sheet.
- Two holes on the flange for fixing by means of screws or rivets.
- To guarantee a better fluency, the felt sealing system is not present.
- Version with the big ball made of plastic material:
 - is particularly suitable to handle gentle surfaces as glass or crystal sheets, wood panels, painted or glazed pressed metal sheets, and so on;*
 - working temperatures 0°/60°.*
- Drain hole at the bottom

ITEM	TYPE	VERSION	DIMENSIONS**									LOAD. (Kg)	WEIG. (Kg)
			dw	D	D1	h	H	b	V	E			
SPS01500BDV	SPS 15 B DV	Body made of zinc plated steel, balls made of AISI 52100 chrome steel	15	24	41	10,8	19,6	3,4	3,5	30	15	0,045	
SPS01500CDV	SPS 15 C DV	Body made of zinc plated steel, balls made of AISI 420C stainless steel	15	24	41	10,8	19,6	3,4	3,5	30	15	0,045	
SPS01500BDDV	SPS 15 BD DV	Body made of zinc plated steel, big ball made of plastic*, small balls made of AISI 52100 chrome steel	15	24	41	10,8	19,6	3,4	3,5	30	10	0,034	
SPS01500CDDV	SPS 15 CD DV	Body made of zinc plated steel, big ball made of plastic*, small balls made of AISI 420C stainless steel	15	24	41	10,8	19,6	3,4	3,5	30	10	0,034	
SPS02500BDV	SPS 25 B DV	Body made of zinc plated steel, balls made of AISI 52100 chrome steel	25	38	56	14,6	30	3,4	4	45	60	0,13	
SPS02500CDV	SPS 25 C DV	Body made of zinc plated steel, balls made of AISI 420C stainless steel	25	38	56	14,6	30	3,4	4	45	60	0,13	
SPS02500BDDV	SPS 25 BD DV	Body made of zinc plated steel, big ball made of plastic*, small balls made of AISI 52100 chrome steel	25	38	56	14,6	30	3,4	4	45	20	0,075	
SPS02500CDDV	SPS 25 CD DV	Body made of zinc plated steel, big ball made of plastic*, small balls made of AISI 420C stainless steel	25	38	56	14,6	30	3,4	4	45	20	0,075	

** Height Tolerance +/- 0,4 mm
** Diameter Tolerance +/- 0,4 mm

SPECIAL UNITS CUSTOM MADE

Upon request, we can provide other kinds of ball transfer units made to measure to meet your needs for the widest variety of uses and applications.

Our technical department is available to assess the feasibility of various types to satisfy the user's demands and, if necessary, assist the Customer in choosing the correct ball transfer units to use.

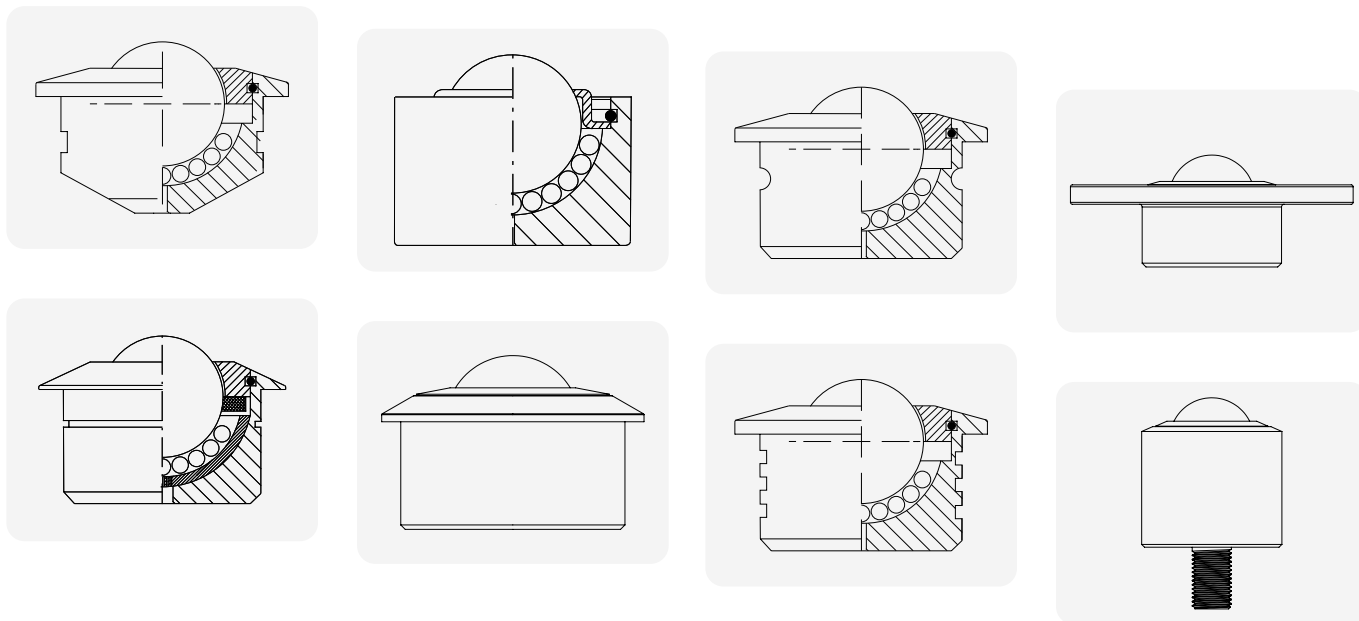

Made-to-measure ball transfer units.

Completely custom, designed with you to provide your applications with maximum performance.

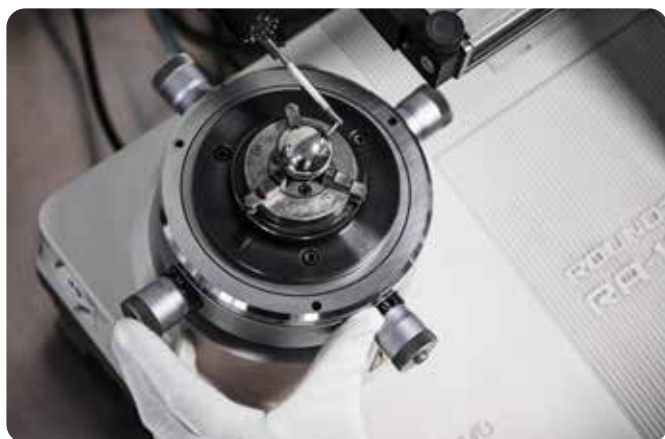

TOLERANCES

BALL TRANSFER UNITS

Diameter Tolerance*		
From	To	Tolerance
0	45	+/- 0,10 mm
46	75	+/- 0,20 mm

Length Tolerance*		
From	To	Tolerance
0	10	+/- 0,20 mm
11	53,5	+/- 0,30 mm

* Valid for all products in the catalog unless otherwise indicated on the relevant page.

FIXING RING

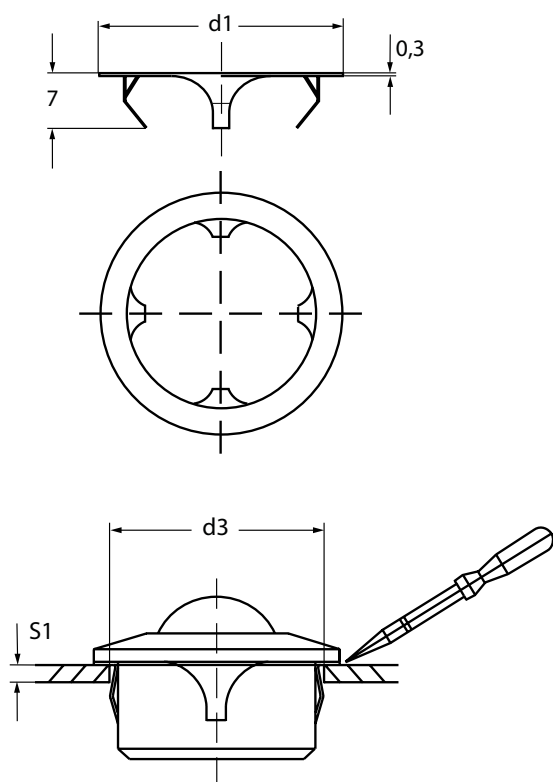

ELASTIC FIXING RING, REMOVABLE VERSION

TYPE	D1	D3	S1
SPM - SPS 15	30,50	25 - 0,2	2 - 3 mm.
SPM - SPS 22	44	37,3 - 0,3	2 - 4 mm.
SPM - SPS 30	54,80	46,7 - 0,4	2 - 4 mm.

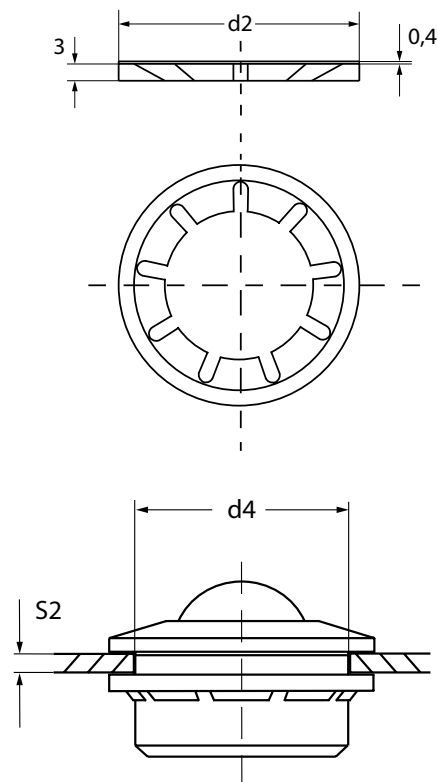

FIXING RING, FIXED VERSION

TYPE	D2	D4	S2
SPM - SPS 12	36,50	25 - 0,2	2 - 4 mm.
SPM - SPS 15	41,50	25 - 0,3	2 - 6 mm.
SPM - SPS 30	60,00	46 - 0,4	2 - 15 mm.



**MAKE
YOUR
WORLD
MOVE**

® RGPBALLS S.r.l.

Via E. De Amicis 59/C 61/A,
20092 Cinisello Balsamo (MI) - Italia

P.I. / C.F. / Reg. Impr. 08678490965
N. REA: MI-2042305
Cap. soc. € 500.000 int. vers.

 +39 02 6178 857 / +39 02 6601 7032 / +39 02 6129 4593

 rgpballs@rgpballs.com

 www.rgpballs.com

RGPBALLS®